

Composite Steel Joists

DAVID SAMUELSON

Composite steel construction has been recognized for a number of years as one of the most economical systems for constructing building floors. Three options have evolved over the years to meet the requirements for building height limitations and the need to run complex heating, ventilating, electrical, and communication systems: (1) Composite wide flange beams with web openings; (2) Stub girders; and (3) Open web steel joists and joist girders. This paper focuses on the advantages associated with composite open web steel joists, development and testing of open web steel joists, behavior of welded shear studs observed while testing composite joists, case histories of projects using composite joists, unique vibration considerations associated with joist floors, and current status of composite joist specification development.

DESCRIPTION

The term composite joist refers to an open web, parallel chord, load carrying member suitable for the direct support of floors in buildings, utilizing hot-rolled or cold-formed steel, including cold-formed steel whose yield strength has been attained by cold working. Shear connection between the joist top chord and overlying concrete slab allows the steel joist and concrete to act together as an integral unit after the concrete has adequately cured. Currently the most commonly used forms of shear connection between the joist top chord and concrete slab include specially rolled cold formed steel "s" shaped top chords (Hambro), specially embossed back-to-back double angle top chords (Vescom), perforated structural tee top chords (Tafrus), and shear studs welded through the metal deck (Canam, SMI, and Vulcraft).

ADVANTAGES OF COMPOSITE JOISTS

Benefits to be gained by using composite steel joists include the following:

- Ability to route the new mechanical heating, ventilating, plumbing, and electrical lines through the joist open webs as shown in Figure 1. Customized web

openings and configurations can be provided for large ducts.

- Ease of relocating and/or moving future HVAC during the life of the building.
- Better plenum space utilization.
- Floor-to-floor height can potentially be reduced by not having to run the mechanical lines under the joists. Also the more efficient and stiffer composite design makes it possible to support a given load with a shallower joist.
- Weight savings resulting from the efficient joist design reduces overall building costs.
- Simplified erection and connections provide for fastest construction.
- Large column free areas give the building tenant maximum flexibility when selecting a floor layout plan.
- Ability to provide customized composite joist designs for any given loading and serviceability requirements.

FULL SCALE TESTING

One of the first references to testing of composite joists is found in a 1965 Master of Science Thesis by H.G. Lembeck Jr. (Lembeck, 1965). In these test specimens, the double angle joist top chord was lowered to allow the round rod web members to extend into the concrete slab and form a shear connection with the overlying slab. Corrugated steel

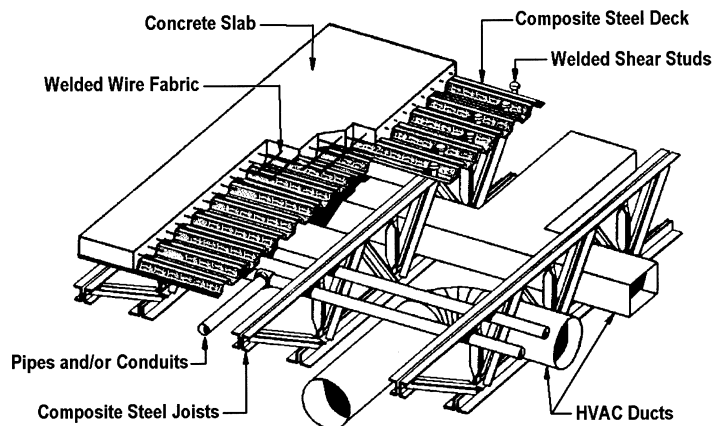

Fig. 1. HVAC ducts and piping passing through joist open webs.

David Samuelson is structural research engineer, Nucor-Research and Development, Norfolk, NE.

Table 1. Description of Tests Performed on Composite Joists

Test No.	Joist Depth (in.)	Joist Span (ft)	Top Chord	Bottom Chord	Deck Type	Slab Thickn'ss Above Deck (in.)	f'_c (ksi)	γ_c (pcf)	Slab Width (in.)	Studs (No. – Dia.)
CJ-1 ¹	21	36	2L-3x3x.227	2L-3.5x3.5x.344	2VLI	4	4.86	145	96	37-3/4
CJ-2 ¹	21	36	2L-3x3x.227	2L-3.5x3.5x.344	2VLI	4	4.11	145	96	37-3/4
CJ-3 ¹	8	24	2L-2x2x.187	2L-3.0x3.0x.250	1.5VL	2.5	3.97	145	72	26-5/8
CJ-4 ¹	20	22.5	2L-1.75x1.75x.188	2L-2.5x2.5x.250	1.5VL	2.5	3.97	145	67	24-5/8
UNL-1 ²	12	36	2L-2x2x.250	2L-3x3x.313	2VLI	1.625	4.31	120	48	22-3/4
UNL-2 ²	12	36	2L-2x2x.250	2L-3x3x.313	2VLI	2	10.97	150	48	22-3/4
CLH-1 ³	36	56	2L-2.5x2.5x.313	2L-3.5x3.5x.313	3VLI	3	4.43	145	102	22-3/4
CLH-2 ³	36	56	2L-2.5x2.5x.313	2L-3.5x3.5x.313	3VLI	3	4.18	145	102	38-3/4
CLH-3 ³	16	40	2L-3.5x3.5x.313	2L-5x5x.438	3VLI	3	4.0	145	81	66-3/4
CLH-4 ³	16	40	2L-3.5x3.5x.313	2L-5x5x.438	3VLI	3	3.1	145	81	44-3/4
CLH-5 ³	34	40	2L-3.5x3.5x.313	2L-3.5x3.5x.313	3VLI	3	5.86	145	81	22-3/4
CLH-6 ³	14	40	2L-3x3x.313	2L-4x4x.438	2VLI	3	4.43	145	81	36-3/4
CLH-7 ³	20	40	2L-3x3x.313	2L-4x4x.438	2VLI	3	5.72	145	81	36-3/4
CLH-8 ³	20	40	2L-3x3x.313	2L-4x4x.438	2VLI	3	5.38	145	81	36-3/4
CLH-9 ³	32	40	2L-3x3x.313	2L-3x3x.313	2VLI	4	3.17	145	81	22-3/4
CLH-10 ³	32	48	2L-3x3x.313	2L-3.5x3.5x.287	2VLI	2.5	3.35	145	81	32-3/4
CLH-11 ³	16	40	2L-3x3x.313	2L-4x4x.438	2VLI	2.5	2.90	110	81	40-3/4
CSJ-5 ³	12	30	ST-2x3.85	2L-2.5x2.5x.212	1.5VL	2	4.40	145	40	12-3/4
CSJ-6 ³	18	30	2L-1.5x1.5x.123	2L-2x2x.163	1.0C	3	4.2	145	40	22-1/2
CSJ-7 ³	18	30	2L-1.5x1.5x.123	2L-2x2x.163	1.0C	3	3.6	145	40	12-1/2

¹Test performed at University of Minnesota, Minneapolis, MN (Alsamsam, 1988; Curry, 1988)

²Test performed at University of Nebraska-Lincoln, Lincoln, NE (Patras, Wayne, and Azizinimini, 1991)

³Test performed at Virginia Polytechnic Institute and State University, Blacksburg, VA (Nguyen, Gibbings, Easterling, and Murray, 1992; Gibbings and Easterling, 1991; Lauer, Gibbings, Easterling, and Murray, 1996)

forms resting on the horizontal legs of the top chord angles supported the concrete slab.

Galambos and Tide (Galambos and Tide, 1970) performed tests on five composite joists that used 3/8-in. (9.5 mm) diameter × 2-in. (51 mm) long shear studs welded to the joist top chords. A solid 3-in. (76 mm) thick concrete slab was supported by each joist. Ductile yielding of the bottom chord near midspan was the typical failure mode.

Stelco (Cran, 1972; Atkinson and Cran, 1972) tested composite steel joists supporting 1 1/2-in. (38 mm) deep steel deck. Results from their economic study suggested that for joists spaced more than 5 ft (1,524 mm) apart and with joist spans greater than 36 ft (10.97m), that composite joists were more economical than noncomposite joists.

In the early 70s Azmi (Azmi, 1972) tested six composite joists with a slab supported by metal deck. Each joist spanned 50 ft with different configurations for the top chord tested including a hot rolled hat shape, cold-formed hat shape, and a hot rolled double angle. Predicted test results

agreed with analytical results and an ultimate design method was developed which matched experimental results.

Robinson and Fahmy (Robinson and Fahmy, 1978) studied the case of partial composite open web steel joists in which the shear connection provided is not sufficient to balance the tensile yield strength of the bottom chord. In the case of a partial composite design, failure typically occurs with the top chord reaching its buckling capacity prior to full yielding of the joist bottom chord. A design methodology is presented for calculating the ultimate capacity of a composite joist with partial shear connection.

Leon and Curry (Leon and Curry, 1987; Curry, 1988), and Alsamsam (Alsamsam, 1988), tested four 36-ft (10.97 m) long composite joists supporting 2-in. (51 mm) composite steel deck. Results from these tests indicated that the composite beam model could be used for predicting the moment capacity of composite joists.

Brattland and Kennedy (Brattland and Kennedy, 1992) tested two composite trusses spanning 37.7 ft (11.5 m) sup-

porting 3-in. (76 mm) wide rib profile steel deck. Flexural models for the composite trusses were presented.

Extensive testing of composite joist behavior has been sponsored by Nucor Research and Development at the University of Minnesota, University of Nebraska-Lincoln, and Virginia Polytechnic Institute and State University as shown in Table 1.

MOMENT CAPACITY MODEL

The moment capacity of a composite joist can be calculated using the simple model shown in Figure 2.

$$T = C \quad (1)$$

$$C = 0.85 f'_c b_e a \quad (2)$$

$$a = T / (0.85 f'_c b_e) = A_s F_y / (0.85 f'_c b_e) \quad (3)$$

$$d_{\text{effective}} = \text{Joist Depth} + \text{Deck ht.} + t_{\text{slab}} - y_{\text{bar}} - (a/2) \quad (4)$$

$$M = T d_{\text{effective}} \quad (5)$$

Very little additional moment capacity is achieved if one includes the top chord in the moment capacity calculations. With the centroid of the top chord being close to the center of the compressive block in the overlying concrete slab, the top chord develops a small moment couple. Also, including the top chord results in a large increase in shear connection requirements that generally are not economical for the small gain in moment capacity.

Good references discussing detailed design procedures for composite joists are listed in the references section of this paper (ASCE, 1996; CISC, 1984; Viest, Colaco, Furlong, Griffis, Leon, and Loring, 1997; CISC, 1997).

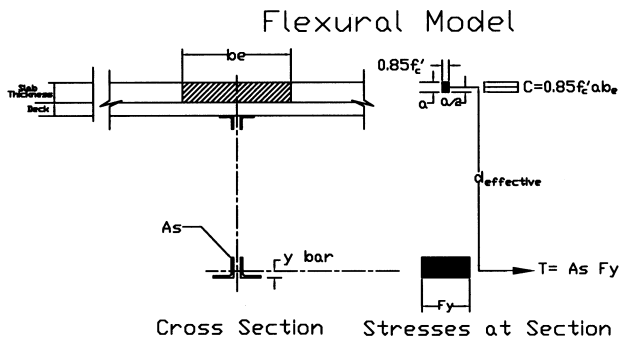

Fig. 2. Composite Joist Flexural Model

BEHAVIOR OF SINGLE WELDED SHEAR STUDS IN METAL DECK

When testing specimen CLH-4, the end shear studs on one half span punched through the side wall of the steel metal deck at a load less than the anticipated joist moment capacity. Examination of the concrete on the interior side of the shear studs, between the single shear studs and the metal deck, revealed that the concrete was crushed and punched through the side wall of the deck as shown in Figure 3.

In examining the shear studs placed on the joist, it was noted that all the single shear studs were placed on the same side of the 3VL deck stiffening rib over the full length of the span. Installing the shear studs in this manner happens very easily as one starts on one side of the deck stiffening rib and simply stays on that side of the stiffening rib until reaching the opposite end of the span. Unfortunately such an installation procedure results in a full half span of studs all installed in the “weak position” as shown in the lower part of Figure 4.

When installing shear studs on composite metal deck with a center stiffening rib, ideally, one installs the studs all on the “strong” side of the deck stiffening rib as shown in the upper part of Figure 4. When reaching midspan on a joist designed for a uniform load, the location for the shear studs switches to the other side of the deck stiffening rib. In other words, one places the stud on the side of the deck stiffening rib closest to either joist end reaction. In the case of a composite joist carrying concentrated loads, one places the studs on the side of the deck stiffening rib away from the point of maximum moment.

If one does not want to change the positioning of the shear stud at midspan, a compromise solution is to alternate the location of the shear studs either side of the deck stiffening rib along the full length of the joist. This will provide half “weak” and half “strong” position shear studs, which is substantially better than all “weak” studs.

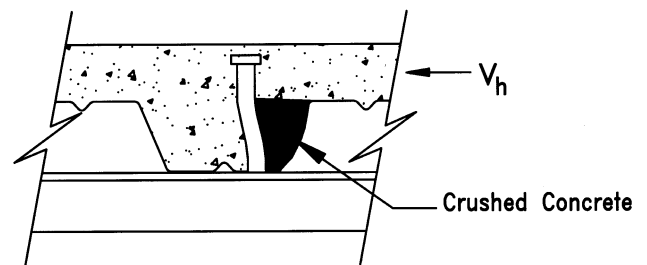

Fig. 3. Concrete Crushing for Weak Positioned Shear Studs

A question commonly raised is "How does one know where to change positioning of shear studs as you approach the center of the span?" In the author's opinion, in the middle quarter span it makes little difference whether the studs are installed on the "weak" or "strong" position. It is the end quarter span where the largest share of the shear transfer occurs, and it is in this end quarter span where it is important that the studs not all be installed in the "weak" position.

Examination of the bent shapes of the shear studs following full scale load tests always show that the studs near the ends of the joist spans carry far greater shear loads than the interior shear studs, with the studs near midspan carry-

ing very little load. Studs are bent over progressively less as one moves from the end reaction toward the center of the span. When one reaches midspan the studs typically are not deformed or bent in any manner, indicating that they were carrying small shear loads. The shear studs ductility allows the highly loaded end studs to deform and distribute additional shear loading to adjacent interior studs.

BEHAVIOR OF SHEAR STUDS ON COMPOSITE BEAMS

The shear stud behavior observed in CLH-4 is not unique to composite joists. A research project (Easterling, Gibbings,

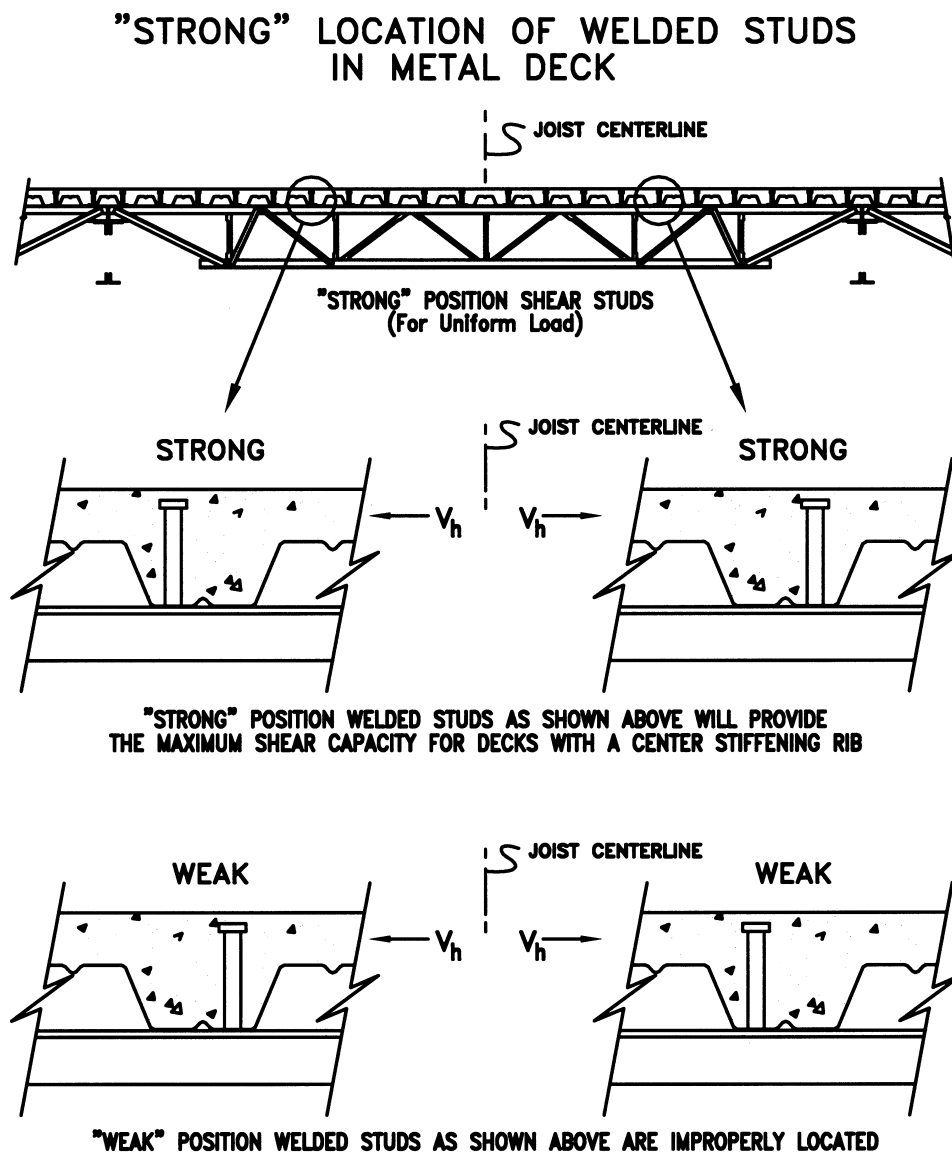

Fig. 4. "Weak" and "Strong" Positioned Shear Studs

and Murray, 1993) at Virginia Polytechnic Institute and State University (VPI) in 1993 funded by AISC with material furnished by Virginia-Carolinas Structural Steel Fabricators Association, Vulcraft-Division of Nucor, and Nelson Stud Welding, Division of TRW, studied in greater detail the effect of “strong” versus “weak” single studs/rib. A total of 8 push-off specimens were fabricated, four with single studs per rib in the weak position and four with single studs per rib in the strong position. Four single W16×31 composite beams spanning 30 ft (9.14 m) were tested with single studs placed all strong, all weak, or alternating strong and weak in 3-in. (76 mm) deep composite deck. Results from these tests (Easterling, Gibbings, and Murray, 1993) showed close correlation between pushout and full-scale beam tests. Ratios of experimental to calculated shear stud strength values varied from 0.59 (weak position) to 0.83 (strong position), with ratios of experimental to calculated moment values varying from 0.85 (weak position) to 0.94 (strong position).

In 1997 an additional three-year research study was initiated at VPI to study the strength of headed shear studs placed in cold-formed steel deck, co-sponsored by AISI, SDI, AISC, Tru-Fit Products Corp., and Nucor R & D. Additional push-out testing to evaluate additional key parameters, performing more full scale beam tests, and development of a revised or new prediction equation for shear studs in metal deck is part of this project.

CASE HISTORIES OF SEVERAL PROJECTS USING COMPOSITE STEEL JOISTS

Reed Arena, Texas A & M University, College Station, TX

In May 1998, Texas A & M University completed Reed Arena, providing a new arena and special events center on the College Station campus. This \$35 million facility provides 12,500 seats for special events, student convocations, concerts, sporting events, and conferences.

Composite steel joists support the 12,000 ft² (1,115 m²) floor level office and conference room area on the end of the oval-shaped arena. Walter P. Moore and Associates, Inc. and D.Y. Davis Associates, both from Houston, Texas were structural engineers for this project. Lockwood, Andrews, and Newman from Houston, Texas were project architects.

Spanning 83 ft (25.3 m) and spaced on 8-ft (2.44 m) centers, the shallow 33-in. (838 mm) deep composite joists have a span/depth ratio of 30.2 minimizing floor-to-floor height. Two-in. (51 mm) high 19 Ga. (1.06 mm) composite steel deck supports the concrete slab with an overall depth of 6.25 in. (159 mm). Reinforcing steel, consisting of one layer of 0.375-in. (9.5 mm) diameter bars at 12-in (305 mm) centers each way, was placed in the concrete slab. Loading supported by the joists includes a dead load of 68 psf (3.26

kPa) plus a live load of 100 psf (4.79 kPa). Lightweight concrete was specified with $f'_c = 4$ ksi (27.6 MPa). Top and bottom chord angles were typically 2L-4 in. × 4 in. × 0.438 in. (2L-102 mm × 102 mm × 11.13 mm) and 2L-6 in. × 6 in. × 0.750 in. (2L-152 mm × 152 mm × 19 mm), respectively. Shear transfer between the overlying concrete slab and composite joists was accomplished by welding 0.75-in. (19 mm) diameter × 5-in. (127 mm) long shear studs through the metal deck.

Advantages for using the composite joists on this project included a cost savings of \$50,000 compared to alternate floor systems, ability to span the 83 ft (25.3 m) with a shallow depth, and ease in erecting the joists.

312 Elm Street, Cincinnati, OH

Construction of the 26-story 312 Elm Street building in Cincinnati, OH used composite joists. The lower ten stories of the building consist of a cast-in-place concrete parking garage, 410,000 ft² (38,090 m²). The upper 16 steel-framed office floors 326,000 ft² (30,290 m²) are supported by composite joists spanning 48.5 ft.

Duke Construction Management, Indianapolis, IN was the developer and was the major contractor for this project. Stanley D. Lindsey and Associates, Atlanta, GA provided all structural engineering services. The anticipated budget for this building was approximately \$60 million with an anticipated construction schedule of 16 months. Use of the composite joists, along with excellent coordination among the various building disciplines, cut the anticipated cost by 4 percent along with finishing the building 6 weeks ahead of schedule (Corrin, 1993).

The composite joists have a depth of 32 in. (813 mm) and are spaced 10 ft (3.05 m) on center. 2VLI 20 Ga. (0.924 mm) deck supports the slab having a total depth of 4.5 in. (114 mm). Normal weight concrete having an f'_c of 3 ksi (20.7 MPa) was specified. An average of 3³/₄-in. (19 mm) × 3¹/₂-in. (89 mm) shear studs were field-welded to the top chord of each composite joist through the metal deck. Typical top and bottom chords are 2L-3 × 3 × 0.300 (2L-76 mm × 76 mm × 7.6 mm) and 2L-3.5 × 3.5 × 0.279 (2L-89 mm × 89 mm × 7 mm), respectively.

Spray applied fireproofing was applied to each joist to satisfy the safety requirements of UL Assembly N825. To minimize overspray, a screen mesh was fastened to one side of the joists. The unprotected 4.5 in. (114 mm) normal weight composite slab did not provide the required 2-hour fire rating by itself. When comparing the cost of fireproofing the deck versus using lightweight concrete, a projected savings of \$44,300 could be obtained by fireproofing the deck (Corrin, 1993).

Initial designs for this building consisted of a cast-in-place post-tensioned concrete skip-joist system similar to the parking garage. Further studies however, suggested that

this was not the most economical option. Estimated cost for the concrete option was \$14.22 per square foot with a construction time of 61 weeks. The selected steel-framed office option with composite joists was estimated at \$13.83 per square foot with a 56-week construction period. Net estimated savings of \$280,000 and a 5-week shorter construction period were estimated prior to construction.

In addition to the economic savings, the primary advantage for using the composite joists on this project was the ability for such long spans to reduce the overall floor-to-floor heights. Particularly for such multi-story buildings, saving as little as 6-in. (152 mm) per floor can provide an additional floor to rent for the building owner. The mechanical ductwork, pipes, and sprinkler lines were easily fed through the joists instead of routing them under, as is the case for other construction methods. Comments received from the steel erector indicated that the erection and constructability of the composite joist system was excellent with little interference between the joists and mechanical lines.

One unique design criteria for these office floors was that the floors be capable of carrying an additional future 50 psf (2.39 kPa) at any location. The composite joist top chord, webs, and shear studs were designed to carry 185 psf (8.84 kPa), while the bottom chord was designed to support 135 psf (6.45 kPa) which was the current anticipated design loading. In the future the loading can be increased by an additional 50 psf (2.39 kPa) by simply adding steel cover plates to the underside of the bottom chords of the joists in the designated floor areas. Full scale load testing of a typical composite joist for this project, test specimen CLH-10, shown in Table 1 verified this multiple load carrying capability prior to fabrication of the composite joists.

Using composite joists on this project provided a very stiff floor system. A calculated system frequency of 3.59 Hz and a maximum calculated amplitude of 0.0119 in. (0.30 mm) under a heel drop were estimated. Using the Modified Reiher-Meister scale, the floor falls in the "slightly perceptible" category. Reports received indicate that the in-place vibrations of the floor system are actually less than anticipated.

1000 De La Gauchetiere Building, Montreal, Canada

In the initial design stages of the 1000 De La Gauchetiere building, the building was all concrete. The large and repetitive floor areas spanning 49.2 ft (15 m) allowed for a steel alternative wherein the concrete elevator core provided lateral resistance along with the gravity steel frame located on the perimeter of the building.

The floor framing is composed of joist and girder composite elements with the majority of the 800 composite open web steel joists spanning 49.2 ft (15 m) and spaced at 10-ft (3.05 m) centers. The concrete slab is 6-in. (152 mm)

deep measured from the bottom of the 3-in. (76 mm) deep 20 Ga. (0.91 mm) composite deck profile.

Special framed end connections were fabricated on the ends of the composite joists so that the top chord of the joists and girders are flush with one another. By making the exterior girders composite, the increased stiffness and load carrying capacity made it possible to more economically carry the curtain walls.

Loads supported by the floor include a slab, deck, and joist dead load of 63 psf (3.0 kPa), mechanical and partition composite dead load of 29 psf (1.4 kPa), and reducible live load of 80 psf (3.84 kPa). For the 49.2-ft (15 m) span by 10-ft (3m) tributary width, the live load was reduced to 77 percent of the 80 psf.

Top chords of the composite open web joists consist of W7×13 (WT180×19.5) with a 44 ksi (300 MPa) yield strength. The bottom chord consists of 2L-3.0 in. × 2 in. × 0.375 in. (2L-76 mm × 51 mm × 9.5 mm) with the short legs back-to-back separated by 0.375-in. (9.5 mm) gusset plates. The web members were made using double angles. The vertical stem of the WT top chord allows for a good weld length and the T-section was selected to assure a continuous 5-in. (127 mm) wide surface for stud welding.

The large center panels with the webs installed according to a modified Warren geometry allows for easy passage of sprinkler piping and ventilation conduits. The use of a long end panel with the end diagonal lined up with the compression in the concrete slab resulted in good composite action and a larger space for installation of ventilation ducts in the ends of the joists. This longer end panel was designed non-compositely.

Overall depth of the steel joists is 36 in. (920 mm) with a 1³/₈-in. (35 mm) camber. The composite section with an overall depth of 42 in. (1,070 mm) provides for a stiff floor without annoying vibrations. Twenty-two-³/₄-in. (19 mm) diameter × 4¹/₂-in. (115 mm) shear studs per span were welded through the 20 Ga. (0.91 mm) galvanized metal deck.

Associated Wholesale Grocers, Kansas City, KS

With Associated Wholesale Grocers rapidly growing business, additional office space was needed. Composite joists were selected to support second and third level office floors after considering several solutions offered by George Butler and Associates, Project Architects, Kansas City, KS and A.T. Renczarski and Co., Structural Engineers, Kansas City, MO. One of the critical design requirements was that the construction work could not in any way interfere with the computer center located on the ground floor, which was used on a continual basis for processing customer orders. Also the existing heating and ventilating units located on the existing roof could not be shut down during the construction process.

The new second and third floor office addition had a footprint of 117 ft 9 in. (35.9 m) × 185 ft (56.4 m) providing an additional 43,570 ft² (4,048 m²) of office space. Composite joists were selected to simply span 117 ft 9 in. (35.9 m) over the entire first floor level thereby not disturbing any office activities. Steel columns supported by auger-cast pilings were erected immediately adjacent to the perimeter of the existing building. The composite joists and noncomposite joist girders provided a moment resisting frame for the building.

Second story composite joists have a depth of 80 in. (2,032 mm), with these deeper joists straddling the rooftop HVAC equipment. Design loads for the floor consist of 61 psf (2.92 kPa) noncomposite dead load, 50 psf (2.39 kPa) composite live load, and 24 psf (1.15 kPa) composite dead load (4 psf [0.19 kPa] mechanical and 20 psf [0.96 kPa] partitions). Portions of the floor were designed to support large moving files with a live load of 125 psf (5.99 kPa). To minimize any problems with differential live loading deflections, the maximum differential deflection between adjacent composite joists was specified not to exceed 0.5 in. (12.7 mm). Composite joists were cambered for 100 percent of the noncomposite dead load deflection plus 25 percent of the composite live load deflection.

Second story composite joist top and bottom chords are typically 2L-4.0 × 4.0 × 0.500 (2L-102 mm × 102 mm × 12.7 mm) and 2L-6.0 × 6.0 × 0.625 (2L-152 mm × 152 mm × 15.9 mm) angles respectively, with a minimum yield stress of 50 ksi (345 MPa). Angle webs for the composite joists were arranged in a modified Warren configuration with a 5-ft (1,524 mm) half-panel length. Shear transfer to the overlying 5-in. (127 mm) deep concrete slab was accomplished by welding 46 to 88³/₄-in. (19 mm) diameter × 4-in. (102 mm) long shear studs through the metal deck onto each composite joist. Joists were spaced 8 ft 8 in. (2.64 m) apart and support a 2-in. (51 mm) deep 20 Ga. (0.909 mm) composite steel deck. A design f'_c of 4 ksi (27.6 MPa) was specified for the normal weight concrete slab.

When designing such long floor and roof joists, special considerations need to be given to the following items:

- Transverse differential deflections between adjacent joists and/or points that do not move vertically need to be carefully examined.
- When placing the concrete for such a long span floor, it is suggested that the concrete be placed at a constant thickness versus trying to establish a constant surface elevation for the slab. Ideally the concrete placement starts near the center of the span and progresses toward either end of the joist. If one attempts to place the concrete at a preset elevation, initial concrete thicknesses will be less than the specified minimum thickness until the majority of the joist camber has been removed under full noncomposite load of the wet concrete. Likewise slab surface elevations will con-

tinue to move downward until the full span has had all the concrete placed.

- Long term deformations due to creep and shrinkage within the concrete slab should be calculated and potentially included in the joist camber required. One method for estimating creep and shrinkage is to use a modulus of elasticity of the concrete equal to one half of its normal value (AISC, 1991). This reduced modulus of elasticity is utilized when calculating deflections from loads applied after the concrete has hardened.
- Partitions, piping, risers, electrical conduits, and HVAC ducts between floors ideally should be framed to allow differential vertical movement in the likely case that the floors or the roof do not have equal live load applied to them.
- When bridging such long span joists, it is suggested that diagonal bridging not be used in the last exterior joist space. For this last joist space it is suggested that horizontal bridging be used or a vertical slip connection be provided between the bridging and the spandrel joist.

VIBRATIONAL CHARACTERISTICS OF FLOORS CONSTRUCTED USING COMPOSITE JOISTS

The vibration properties of composite joists can be calculated following the guidelines outlined in Steel Design Guide Series No. 11, *Floor Vibrations Due to Human Activity*, published by the American Institute of Steel Construction, Inc. (Murray, Allen, and Ungar, 1997). Section 3.6 of Design Guide 11 discusses special considerations which need to be taken into account when analyzing floors supported by open web joists and joist girders which are also applicable for composite joists. Research has shown that the effects of web shear deformation and joint eccentricity cause a reduction in the theoretical moment of inertia for joists, while those same factors plus joist seat flexibility cause a reduction in theoretical joist girder moment of inertia.

In the case of a normal double angle joist seat, testing has shown that the joist seats are laterally flexible and are not stiff enough to transfer 100 percent of the shear from the joist girder into the concrete slab. Murray (Murray et al., 1997) suggests that when calculating the moment of inertia for a joist girder the following equation be applied:

$$I_g = I_{nc} + (I_c - I_{nc})/4 \quad (6)$$

where

- I_{nc} = Noncomposite moment of inertia for the joist girder
- I_c = Composite moment of inertia for the joist girder

Simply stated the composite moment of inertia for a joist girder is equal to the noncomposite moment of inertia plus 25 percent of the difference between the full theoretical composite moment of inertia and the noncomposite moment of inertia.

The standard method for calculating the moment of inertia of a steel joist is to reduce the full noncomposite moment of inertia by multiplying by a factor of 0.85. The 0.85 factor is an average factor to account for web deformation and joint eccentricity which works well at typical span/depth ratios of approximately 18. Examination of numerous full-scale joist load tests (Murray, Allen, and Ungar, 1997) revealed that for high span/depth ratios approaching 24, the web deformation correction factor is closer to 0.9 while at low span/depth ratios of 6 a correction factor of 0.5 is appropriate.

Examining the results of full-scale joist load tests and predicted deflections of joists modeled using a finite element program, Band and Murray (Band and Murray, 1996) suggest the following methodology for calculating the effective moment of inertia for a noncomposite joist or joist girder.

$$I_{\text{mod noncomposite}} = C_r I_{\text{chords}} \quad (7)$$

For joists or joist girders with angle web members, the value of C_r is calculated from Equation 8.

For $6 \leq L/D \leq 24$,

$$C_r = 0.90(1 - e^{-0.28(L/D)})^{2.8} \quad (8)$$

where

L = Span of the joist, in.
 D = Depth of the joist, in.

For joists or joist girders with continuous round rod webs, the value of C_r is calculated from Equation 9.

For $10 \leq L/D \leq 24$,

$$C_r = 0.721 + 0.00725(L/D) \quad (9)$$

Design Guide 11 suggests the following procedure for calculating the composite moment of inertia for a composite joist or joist girder.

$$I_{\text{eff}} = \frac{1}{\frac{\gamma}{I_{\text{chords}}} + \frac{1}{I_{\text{comp}}}} \quad (10)$$

where

$$\gamma = \frac{1}{C_r} - 1 \quad (11)$$

I_{comp} = Combined moment of inertia for the chords and transformed slab

I_{chords} = Moment of inertia for the noncomposite joist or joist girder

For L/D ratios of 15 or above the standard S.J.I. factor of 0.85 gives reasonably accurate estimates of a joist or joist girder's moment of inertia. For L/D ratios below 15 or to estimate a more accurate joist or joist girder deflection, the above outlined correction can be applied.

Detailed examples for calculating vibrational properties for floors supported by joists and joist girders can be found in Design Guide 11. In this vibration analysis, the joists and joist girders are assumed to act compositely so the design methodology is also applicable for composite joists.

Results obtained from measuring three long span composite joist office floors were presented in a paper written by Band and Murray (Band and Murray, 1999). Summarizing from this paper, it appeared that the predicted frequencies using Design Guide 11 tended to be slightly less than the measured floor frequencies. The building floors tended to vibrate at the natural frequency of the joists rather than the combined predicted system frequency for the joists and joist girders. All three measured floors satisfied the criterion of Design Guide 11 and were judged by the four-person measurement team and occupants to be "satisfactory."

SPECIFICATIONS FOR COMPOSITE JOISTS

At the present time there is no universal, approved specification for composite joists in the United States. Each composite joist manufacturer (Hambro, Vescom, Taftrus, Vulcraft, SMI, etc.) typically follows their own design procedures for their proprietary systems.

The ASCE Task Committee on Design Criteria for Composite Structures in Steel and Concrete in 1996 published a "Proposed Specification and Commentary for Composite Joists and Composite Trusses" (ASCE, 1996) that addresses the design of simply supported composite joists and trusses used in one-way floor systems. This proposed specification covers design considerations for the bottom chord, top chord, flexural capacity calculations, design of web elements, shear connection, and serviceability criteria along with working through a design example.

At the current time the Steel Joist Institute (SJI) has formed a composite joist committee whose primary goal is to develop a composite joist specification which could be included in the SJI "Standard Specifications, Load Tables, and Weight Tables for Steel Joists and Joist Girders" (SJI, 1994).

CONCLUSIONS

Composite steel floor joist systems provide an economical system for supporting floor loads. Ease in routing HVAC

ducts, plumbing, and electrical lines through the open web system of the joists allows reductions in the overall floor-to-floor height. Composite joists allow longer economical spans. Building tenants highly value the increased flexibility that they have when laying out floor plans unhindered by closely spaced columns. Composite joists have been extensively studied over the last 30 years with models developed that allow the designer to accurately predict the load carrying capacity and serviceability to meet design requirements. Research on composite joists within the United States in the last 10 years has raised the level of understanding for all types of composite construction. The need for current ongoing research to improve the predicted shear capacities for a single shear stud in metal decks with a center stiffening rib was first identified in the initial composite joist tests listed in Table 1 and later confirmed by full scale beam tests. Completed research co-sponsored by AISC, AISI, SDI, shear stud producers, and Nucor will potentially provide designers more conservative predictions for the capacity for single shear studs per rib in modern steel deck profiles used within the United States.

The most current research on vibration of floors supported by composite steel joists is found in AISC Steel Design Guide Series 11, *Floor Vibrations Due to Human Activity* (Murray, Allen, and Ungar, 1997). In this author's opinion, the methodology outlined in this paper and shown in Design Guide 11 provides an accurate calculation for a composite joist's moment of inertia, taking into account varying span/depth ratios and differing web configurations. Measured composite joist floors in three separate buildings tended to vibrate at the natural frequency of the joists rather than the combined system frequency for the joists and girders. Predicted floor vibration behavior following Design Guide 11 matched observations of the building occupants.

The use of composite joists will potentially continue to increase following the development of standard specifications for their design. As is the case with any framing member, repetition of the same composite joist size improves overall economy. Clearly communicating all design information, including loading and serviceability requirements, in the design documents will allow the joist supplier to provide the most optimal design.

REFERENCES

- Alsamsam, I. (1988), *An Experimental Investigation Into the Behavior of Composite Open Web Steel Joists*, Masters Thesis, Department of Civil and Mineral Engineering Institute of Technology, University of Minnesota, MN.
- Allison, H. (1991), *Steel Design Guide Series 5, Low- and Medium-Rise Steel Buildings*, AISC, Chicago, IL.
- American Institute of Steel Construction (AISC) (1994), *Load and Resistance Factor Design Manual of Steel Construction*, Vols. I and II, AISC, Chicago, IL.
- ASCE Task Committee on Design Criteria for Composite Structures in Steel and Concrete (1996), "Proposed Specification and Commentary for Composite Joists and Composite Trusses," *ASCE Journal of Structural Engineering*, Vol. 122, No. 4, April.
- Atkinson, A. H., and Cran, J. A. (1972), "The Design and Economics of Composite Open-Web Steel Joists," Canadian Structural Engineering Conference.
- Azmi, M. H. (1972), *Composite Open-Web Trusses with Metal Cellular Floor*, A Master of Engineering Thesis, McMaster University, Hamilton, Ontario, April.
- Band, B. S. and Murray, T. M. (1996), "Vibration Characteristics of Joist and Joist-Girder Members", Research Report CE/VPI-ST 96/07, Department of Civil Engineering, Virginia Polytechnic Institute and State University, Blacksburg, VA.
- Band, B. S. and Murray, T. M. (1999), "Floor Vibrations: Ultra-Long Span Joist Floors," *Proceedings of the 1999 Structures Congress*, American Society of Civil Engineers, New Orleans, Louisiana, April 18-21.
- Brattland, A., and Kennedy, D. J. L. (1992), "Flexural Tests of Two Full-Scale Composite Trusses," *Canadian Journal of Civil Engineering*, Volume 19, Number 2, April, pp. 279-295.
- Canam Manac Group, 270 Chemin Du Tremblay, Boucherville, Quebec, Canada
- Chien, E. Y. L., and Ritchie, J. K. (1984), *Design and Construction of Composite Floor Systems*, Chapter 5, "Composite Open Web Steel Joists and Trusses", CISC, Willowdale, Ontario.
- Canadian Institute of Steel Construction (CISC) (1997), *Handbook of Steel Construction*, CAN/CSA-S16.1-94, Section 16, "Open-Web Steel Joists", 7th Edition, Willowdale, Ontario.
- Corrin, M. (1993), "312 Elm Street—Innovation Pays Off", *The Military Engineer*, No. 554, January-February.
- Cran, J. A. (1972), "Design and Testing Composite Open Web Steel Joists", *Technical Bulletin 11*, Stelco, January.
- Curry, J. H. (1988), *Full Scale Tests on Two Long-Span Composite Open-Web Steel Joists*, Masters Thesis, Department of Civil and Mineral Engineering Institute of Technology, University of Minnesota, MN.
- Easterling, W. S., Gibbings, D. R., and Murray, T. M. (1993), "Strength of Shear Studs in Steel Deck on Composite Beams and Joists," *AISC Engineering Journal*, Vol. 30, pp. 44-55.

- Galambos, T. V. and Tide, R. H. R. (1970), "Composite Open-Web Steel Joists", *AISC Engineering Journal*, January.
- Gibbings, D. R. and Easterling, W. S. (1991), *Strength of Composite Long Span Joists*, Report CE/VPI-ST91/02, Department of Civil Engineering, Virginia Polytechnic Institute and State University, Blacksburg, VA.
- Hambro Composite Floor System, Canam Steel Corporation, 721 N.E. 44th Street, Fort Lauderdale, FL.
- Lauer, D., Gibbings, D., Easterling, W. S., and Murray, T. M. (1996), *Evaluation of Composite Short Span Joists*, Report No. CE/VPI-ST96/06, Department of Civil Engineering, Virginia Polytechnic Institute and State University, Blacksburg, VA.
- Lembeck, Jr., H. G. (1965), *Composite Design of Open Web Steel Joists*, M.Sc. Thesis, Washington University, St. Louis, MO.
- Leon, R. T. and Curry, J. (1987), "Behavior of Long Span Composite Joists", *ASCE Structures Congress Proceedings*, Florida, August, pp. 390-403.
- Murray, T. M., Allen, D., and Ungar, E. (1997), Steel Design Guide Series 11, *Floor Vibrations Due to Human Activity*, AISC, Chicago, IL.
- Nguyen, S., Gibbings, D. R., Easterling, W. S., and Murray, T. M. (1992), *Further Studies of Composite Long-Span Joists*, Report No. CE/VPI-ST92/05, Department of Civil Engineering, Virginia Polytechnic Institute and State University, Blacksburg, VA.
- Patras, W. and Azizinimini, A. (1991), *Open Web Composite Joist Systems Utilizing Ultra-High Strength Concrete*, Masters Thesis, College of Engineering and Technology, University of Nebraska, Lincoln, NE.
- Robinson, H. and Fahmy, E. H. (1978), "The Design of Partially Connected Composite Open-Web Joists", *Canadian Journal of Civil Engineering*, Volume 5, pp. 611-614.
- SMI Joist Company, Gainesville, FL.
- Steel Joist Institute (SJI) (1994), *Standard Specifications, Load Tables, and Weight Tables for Steel Joists and Joist Girders*, Myrtle Beach, SC.
- Taftrus Composite Techniques, Steel Research, Inc., 2789 152nd N.E., Redmond, WA.
- Vescom Structural Systems Inc., 9 Northern Boulevard, Greenvale, NY.
- Viest, I., Colaco, J., Furlong, R., Griffis, L., Leon, R., and Wyllie Jr., L. A. (1997), Section 3.8, "Composite Joists and Trusses", *Composite Construction Design for Buildings*, Co-published by American Society of Civil Engineers, and McGraw Hill.
- Vulcraft VC Series Composite Joists, PO Box 59, Norfolk, NE.